

Please read before installation work by all means

If you have any questions, please feel free to contact us and we will be happy to answer any questions you may have.

Before installation work, please be sure to check whether there is no scratch, dirt, damage to the appearance.

/ Depending on the product, streaks and dot-like depressions may be seen on the surface

However, it is a thing at the time of molding, and there is not it in abnormality.

/ As it becomes out of the warranty about the trouble about the appearance after the installation beforehand

Please note.

If there is a point of notice at the time of opening, please contact the purchase store before work.

†Precautions at the time of installation†

-The product that comes with the packing, follow the instruction manual and install the packing correctly

Please contact us if you have any questions.

-Do not use chemicals such as diluents or organic solvents when caring for the product. -Do not apply waterproofing treatment such as caulking to the gap between the lens and the housing. Also, please do not disassemble, process, etc. of the product. It is not covered by the warranty.

JEWEL LED TAIL LAMP REVO

Jewel LED Tail Lamp · REVO

For MAZDA RX-8

TMRX8-##-1

Installation and instruction manual

We would like to thank you for your purchase of Valenti products. Please be sure to read this manual to the end before installing it, and make sure that you fully understand how to install and handle it correctly. Please do the installation work and use it.

After reading, please keep it carefully so that you can see the person you use at any time.

Supported models

Manufacturer	Vehicle type	Model	Model year
Mazda	RX-8	SE3P	Previous year H15.4 ~ H20.2 Late H20.3 ~ H25.4

Safety Precautions

The precautions shown here are for the proper use of this product and for the prevention of harm and damage to the customer. You If you have any questions, please feel free to contact us and we will be happy to answer any questions you may have. All of these are important safety issues.

As it is content, please protect it by all means.

⚠ Warning: Any content that is likely to cause death or serious injury to a person if used incorrectly.

⚠ Caution: Any content that is supposed to cause injury to a person and cause only property damage when used incorrectly.

⚠ Warning: It is a matter that there is a risk of serious accidents such as electric leakage, fire. Please read before use.

- Do not attach dust, water droplets, salt, etc. to the connector part. There is a risk of short circuit and fire. Disassembly, repair, remodeling, etc. is absolutely please do not do. There is a risk of fire, injury or breakdown.
- If you notice an abnormality such as smoke or odor from this product, immediately stop the car in a safe place and switch on the ignition switch. Please turn off the lights. The use in the abnormal state may be electric shock and fire.

⚠ Caution: It is assumed that when used incorrectly, only the possibility of injury to a person and property damage will occur.

- When performing work, protect your body with gloves, etc., so that you do not get hurt with sharp parts.
- Do not damage, use, process, forcibly bend, pull, or pinch the power harness.
You can do it. It will cause electric leakage, fire.
- Do not drop this product or give a strong shock. It will cause damage and breakdown.
- Do not wash your car with strong water, such as a high pressure washer. It may cause damage or malfunction.

Valenti
MEU PREMIACCESSORIES

/ Set contents This product consists of the following parts. Please check the set contents.

[RX-8 LED tail lamp body]



LED Tail Lamp Assembly LH x 1



LED Tail Lamp Assembly RH x 1

[Pre-term exclusive parts]



5mm thickness packing left and right x 1 each

[Late exclusive parts]



7mm thick backing left and right x each 1



Screw 13.7mm X2



Screw 10.4mm X2



Stud bolt for packing X2

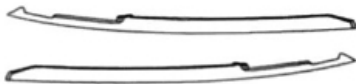

Attachment x2



Key cylinder for nuts



Key cylinder spacer



Stud bolt

[Pre- and post-period common parts]



Aluminum tape: 50mmx150mm x2 sheets



Aluminum Table 15mmx20mm x2 sheets

Necessary tools Necessary tools for the installation of products. As it is not attached, please prepare it.



Socket wrench 10mm, 13mm



Clip Remover Or minus driver



Plus driver

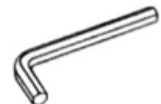

Hex wrench 5mm

Installation method Professional knowledge and technology are required for the installation of this product. We recommend that you request the installation work to a professional trader. The lamp periphery to be removed before starting work so that the vehicle does not get scratched and the place where it is considered to be scratched is sufficiently cured.

Please contact us if you have any questions.

※ Installation work, errors in the use, carelessness, trouble by negligence, damage, water leakage can not take all responsibility.

Tail lamp removal ※ The following becomes the working procedure of the driver's seat side. Do the same on the passenger side.

1. Open the trunk and remove the interior fixing clip on the back of the tail lamp.

*Please work after winding tape etc. on the tip of the minus screwdriver and curing it.

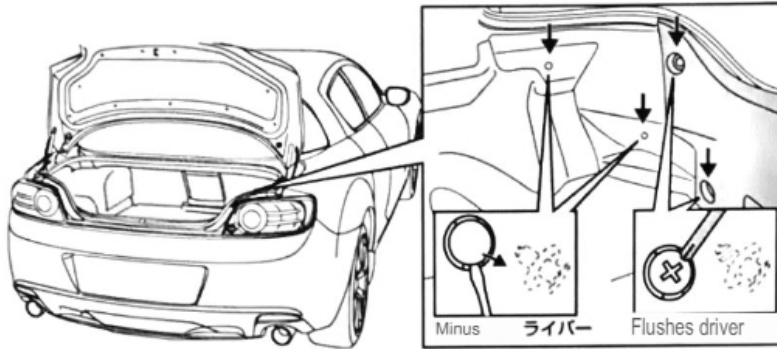

2. Remove the trunk interior panel.

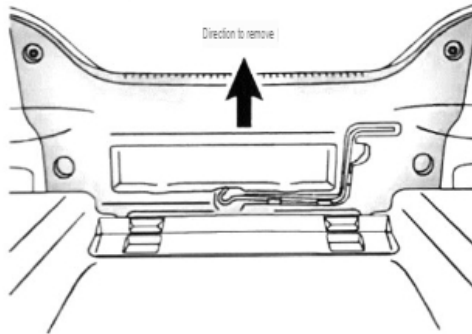

3. Turn over the interior and separate the connectors that are connected to the tail lamp.

Previous car

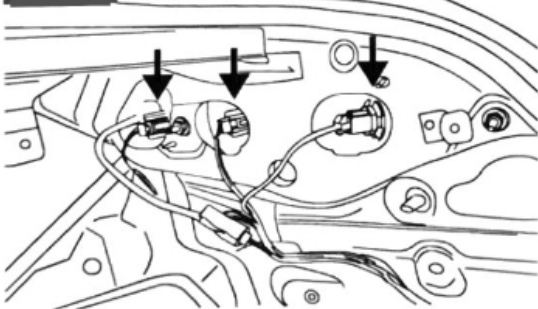

Late car

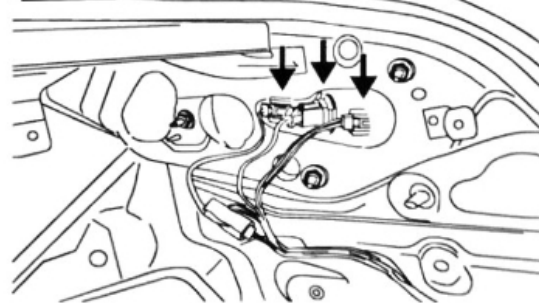

Unscrew the nut that holds the tail lamp with a 4.10mm socket wrench or subana and remove the original tail lamp.

Previous car

2 places

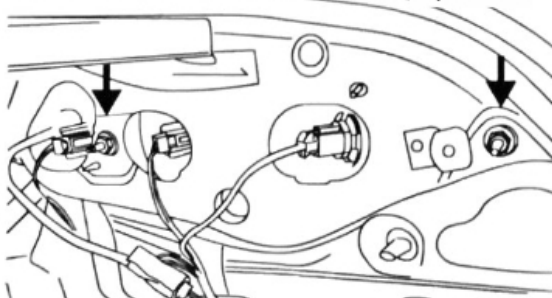

Late car

3 places

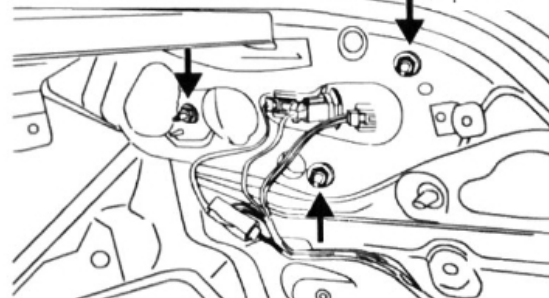

5. Pull the tail lamp to the rear of the vehicle and it will come off.

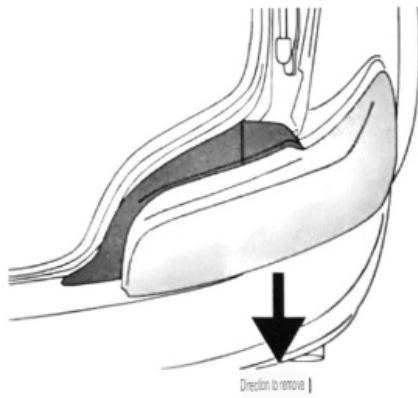

Preparing to Install the LED Tail lamp j

※The following becomes the working procedure of the driver's seat side.Do the same on the passenger side.

Mounting of stud bolts and attachments ※Late car only

Change the position of the stud bolts with a 1.1.3mm socket wrench.
After installing the stud bolts, attach the buckles for the supplied stud bolts.

For late-stage vehicles

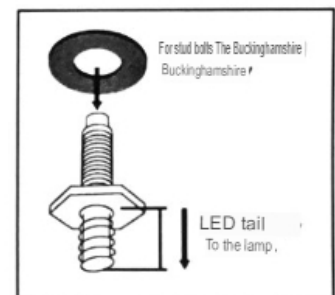
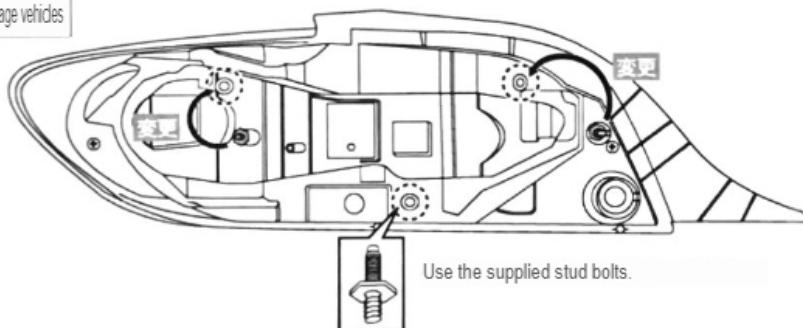

2.Attach the included attachment to the LED tail lamp using the supplied screws with the plus screwdriver. ※As the length of the screw is different by the place to fix it, please be careful.

For late-stage vehicles

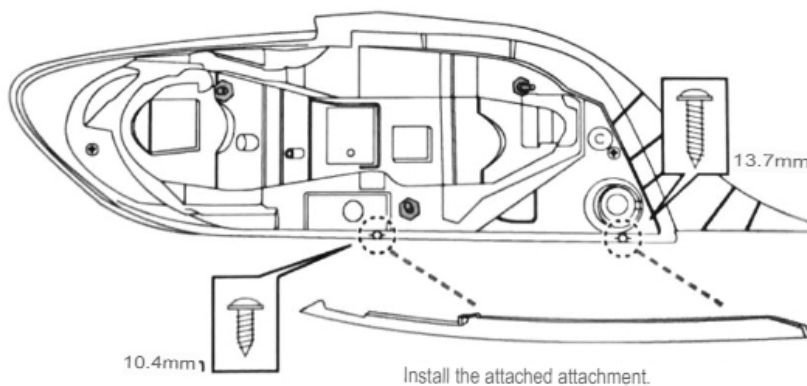

Mounting of buckins

! Caution Previous term vehicle thickness 5mm, late term vehicle thickness 7mm please use the packing.
Please paste it so that it does not deviate or float when pasting the backing. It will cause a water leak.

1. Paste the included backing on the back of the LED tail lamp.
Remove the stinging paper of the packing and stick it firmly so that the position does not shift with reference to the genuine tail lamp.

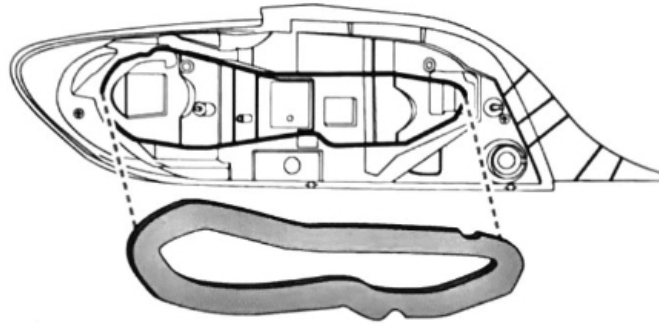

A good example

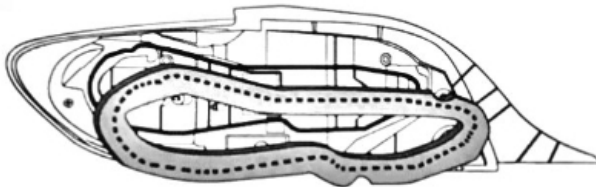

Bad example ※ It causes the water leaf.

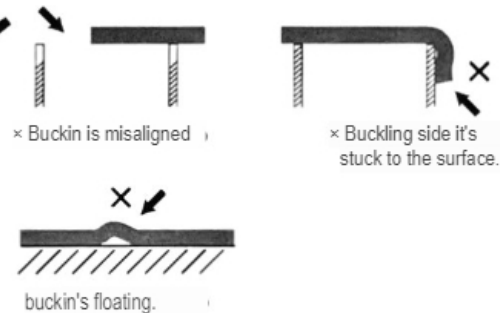
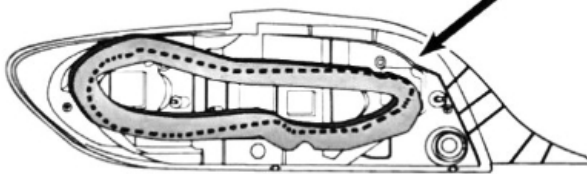

Setting the turn signal

This product can change the lighting pattern of the turn signal by connecting and separating the Giboshi terminal.

※At the time of shipment, the turn signal is set to flow. ※If you set the left and right tail lamps to different settings, it does not conform to safety standards.

Giboshi	Setting the turn signal!
Flowing turn signal to separate	
To connect	Normal flashing

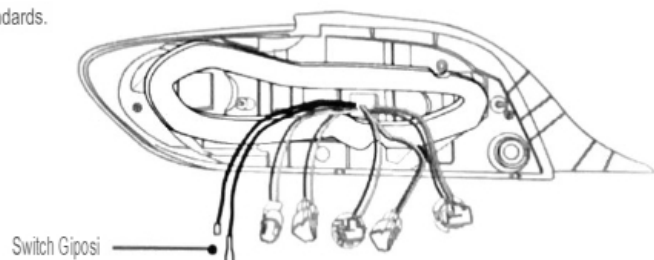

●Partial revision of "Notice to specify Specific Safety Standards for Road Transport Vehicles", etc.
The following amendments are promulgated on Heisei 26 year 10 month 9 day it has become to be applied from the date of enforcement.

[Direction Indicator]

For the direction indicator provided in the front or rear of the car, only those that meet certain requirements, it is possible to point through by chain lighting (sequential lighting) / can be.

/ Wiring connection overview diagram *The figure below is a diagram on one side.

Caution Please be careful not to damage or bend when connecting because the terminal inside the coupler is thin. When connecting, make sure that the shape of the coupler is correct.

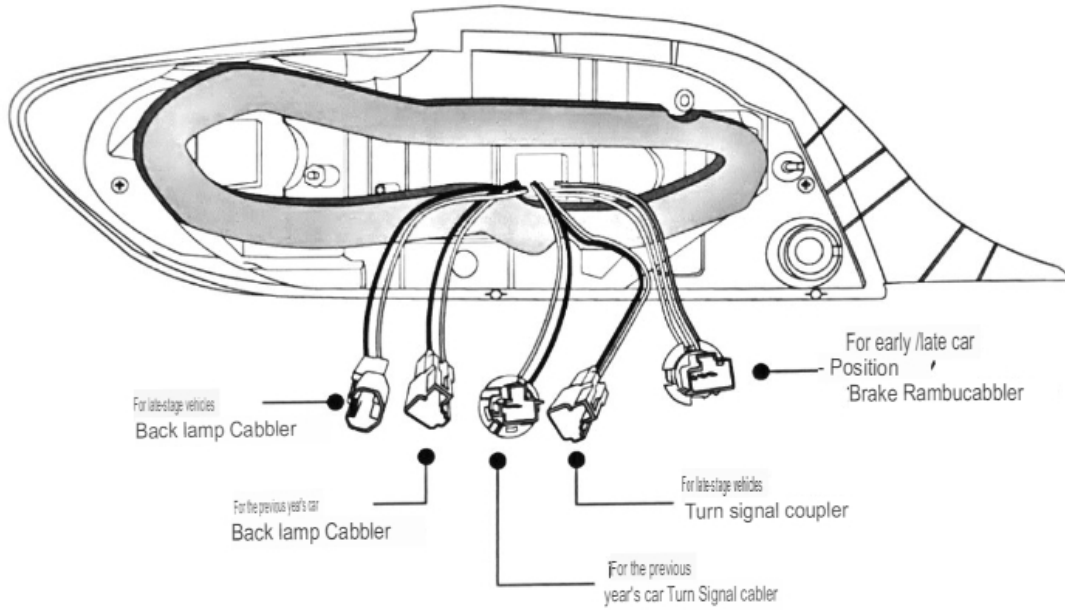

	Position and Brake Coupler	Turn Signal Coupler	Back Lamp Cabler
For the previous year's car			
For late-stage vehicles			

/ Previous year car LED tail lamp installation †

1. To prevent water leakage, attach the attached aluminum tape to the 2 points shown in the figure below (body frame junction surface, body hole).
 *Please stick to the joint surface of the body frame without any gaps. It becomes the cause of the water leak. ※Water leakage due to poor adhesion of the aluminum tape is not covered by the guarantee.

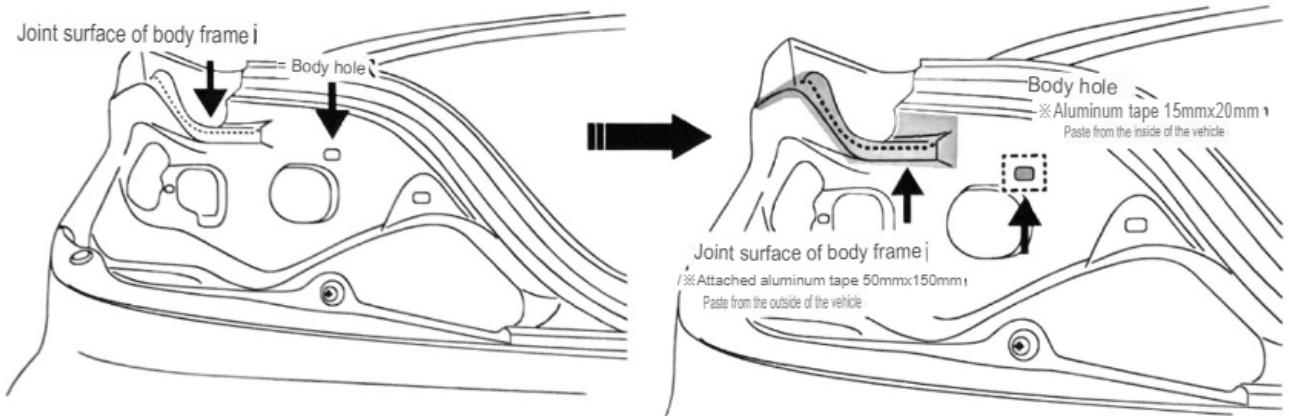

- 2.3. Use the genuine nut to remove the LED tail lamp. Connect the connector of the LED taillamp to the connector of the vehicle side. Please continue.
 Please fix it. ※ Install while checking whether the wiring is not sandwiched

Please contact us if you have any questions.

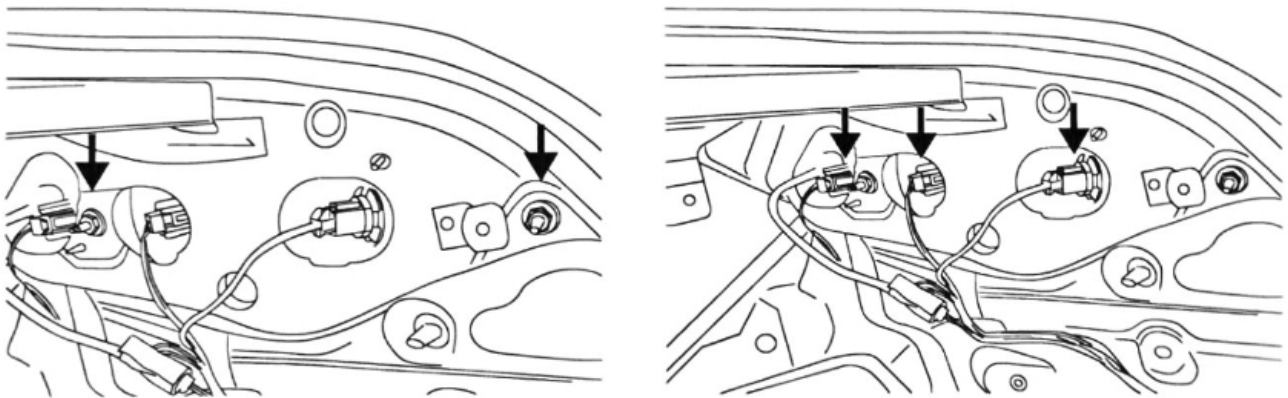

4. Check the lighting of the attached LED tail lamp.
 Check whether the position lamp, brake lamp, and back lamp turn on normally, and the turn signal lamp flashes normally.
 Please contact us.

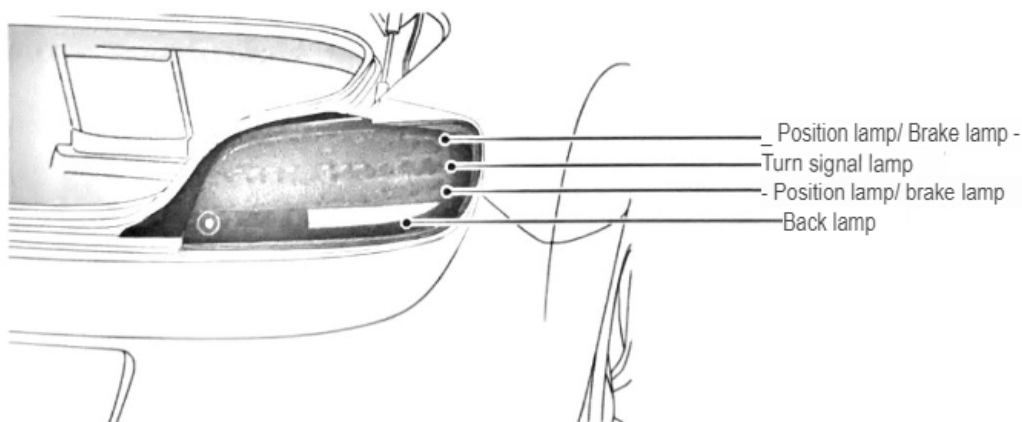

5. If there is no problem with the lighting check, please install the removed interior baht in the opposite procedure to the procedure that was removed.
6. After all the installation is complete, the work is finished.

Late car LED tail lamp installation

1. To prevent water leakage, attach the attached aluminum tape to 1 point (body frame junction surface) shown in the figure below.

⚠ Please stick to the joint surface of the body frame without any gaps. It becomes the cause of the water leak. ※ Water leakage due to poor adhesion of the aluminum tape is not covered by the guarantee.

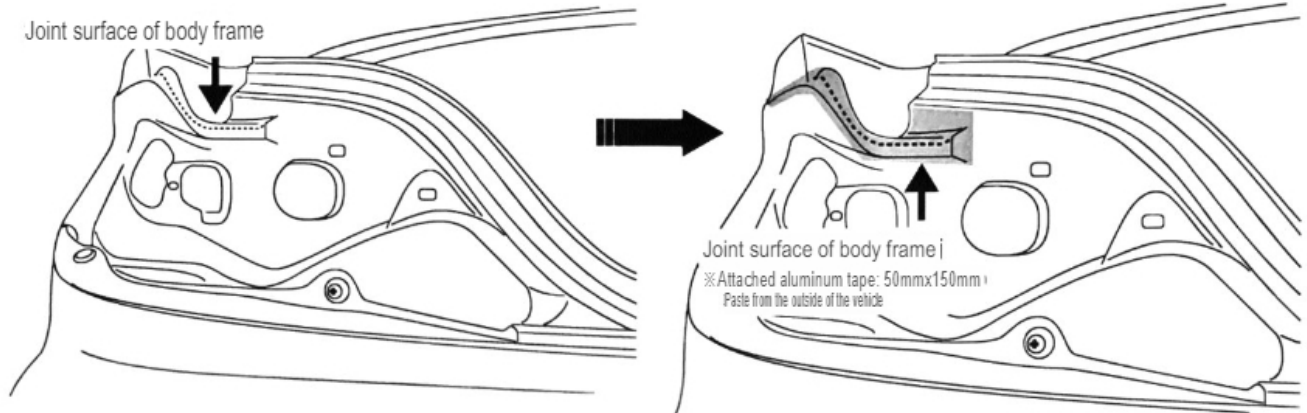

2. Attached key Cylinder spacer installation method

2-1. Remove the nut that holds the key cylinder from the back of the body (tail lamp mounting part), and remove the key cylinder. Please.

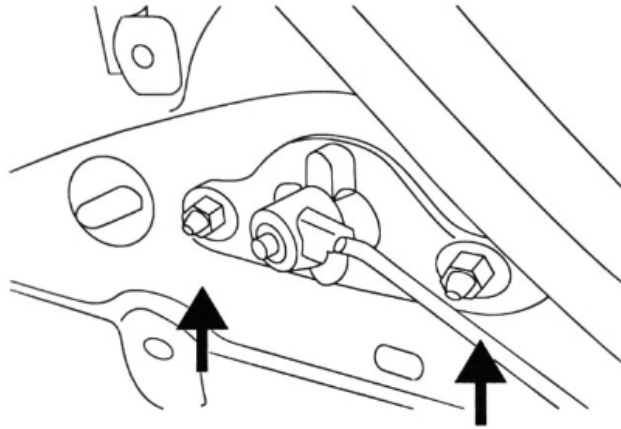

2-2. Use the key cylinder spacer and the supplied nut to temporarily secure the key cylinder.

* Refer to the figure below to make sure that the key cylinder spacer fits between the key cylinder and the body. Use a wrench to temporarily fix it.

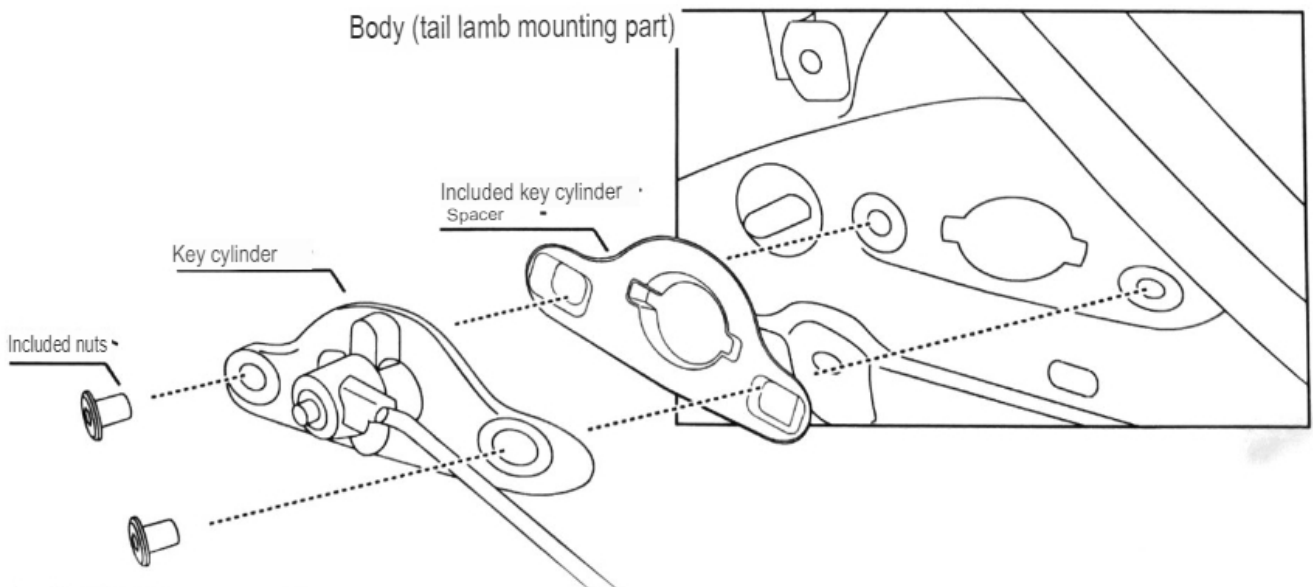

⚠ Caution: The key cylinder is temporarily fixed and the LED tail lamp is installed.

Late car LED tail lamp installation

3. Tighten the nut on the LED tail lamp, then tighten the nut on the key cylinder.

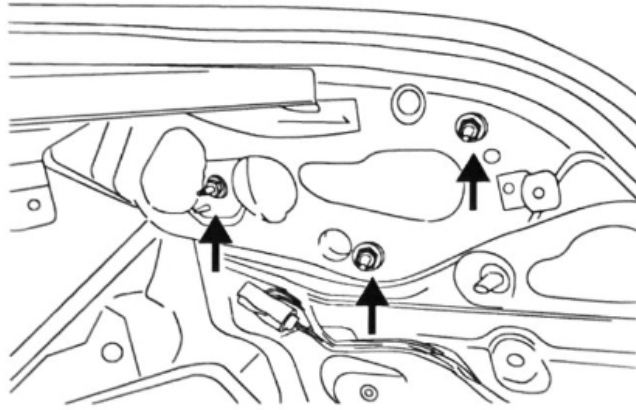

4. Connect the connector of the LED taillamp to the connector on the vehicle side.

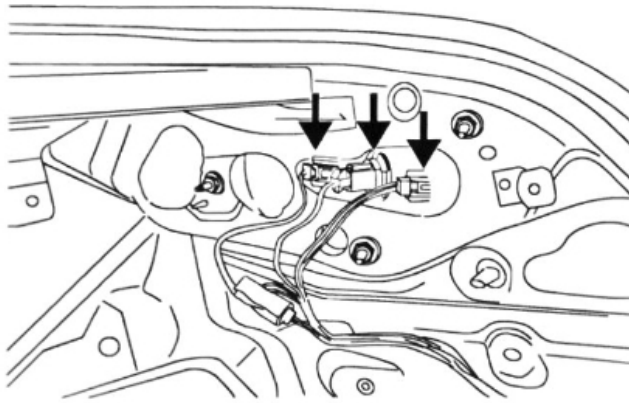

5. Check the lighting of the attached LED tail lamp.
Check whether the fog, brake, and backlight lights up normally, and the turn signal lights blink normally.

Please contact us.

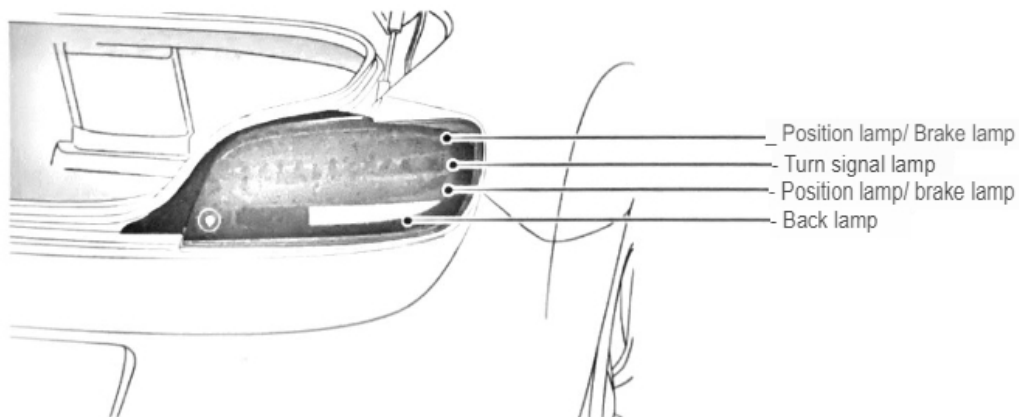

6. If there is no problem with lighting check, please install the removed interior parts in the opposite procedure to the procedure that was removed.

7. After all the installation is complete, the work is finished.

[What you want to protect]

For the safe operation of automobiles, lights such as tail lamps are color and brightness of each light according to the safety standards of the Road Transport Vehicle Act This is the first time I've ever seen a video of a woman in a movie. Please do not change the light color, the modification such as the change of the brightness absolutely.

Be sure to ensure that all lights are working properly before driving the car.

Once the installation is complete, make sure that all lights are working properly.

Please keep the genuine lamp that you removed carefully.

About Product characteristics

About Smoke lens In the case of the LED tail lamp of the smoke lens type, the lens surface may appear white when the LED is lit. This is due to the characteristics of the lens and is not abnormal.

Blur of O-lens

The tail lamp is not sealed because it ventilates the air inside. This allows the heat generated from the lamp to escape and this is to keep the parts in an optimal environment.

The interior of the taillamp is not sealed, so if it rains for a long time or the humidity is high, the interior will become dewy and the lens will be blurred. It is not abnormal. If you leave it for a while, the spider will disappear.

Material of main body

The body is made of ABS resin and the lens part is made of acrylic resin. Do not hit or drop hard objects because they are easy to crack. Please contact us. In addition, please do not wipe the lens with a dry cloth, etc., because the lens part is easy to be scratched.

About the error of the vehicle

There may be a gap of several mm between the body and the tail lamp, but because it is due to body error, installation error, it is different. This is not always the case.

About the turn signal high flash when installing the tail lamp

When using non-Valenti LED products or anti-high flash resistors on the front turn signal, use with the tail lamp. This may result in a high flash (a state in which blinking becomes faster). If a symptom occurs, a separate 5W resistor (our product No.24 VJ1001-TW2-1) to the left and right turn signal wiring 1 Please add one or more front turn signal resistors to our products (our product No.23 VJ1001-TW1-1

You can do it.

About daily care

When attached to the vehicle, please wash off dirt on the surface with water or wipe it off with a soft cloth wet with water. Do not use chemicals such as diluents or organic solvents as they will damage the product. Please go to

the car wash by hand washing. As the high pressure washing causes the water leak, please do not perform absolutely.

Do not intentionally apply strong water flow to the gap between the body and the tail lamp.

[About conformity to safety standards]

This taillamp shall be used in all lights and reflectors provided for in the Specific Notice of Road Transport Vehicle Safety Standards. It is manufactured to conform to the technical standards set forth in this specification, and has been certified by a public certification body as a specific device.

To our customers About our products

The specifications of the product are subject to change without notice. Please understand beforehand.

is it a malfunction?and i thought

In the case of a problem after the following inspection, please contact the dealer or our company.

Stage	symptom	Toko
The lamp is not lit	@Is the coupler firmly connected? Is the ignition switch ON? Is ●the battery fully charged?	O Connect the coupler firmly until the lock is applied. O Turn the ignition switch ON. O Charge the battery or replace it with a new one.
Water leaks the lens sucks.	●Is the tail lamp fixed correctly? ●Will it be eliminated naturally in about a week? @Is the buckin properly attached to the console? ●Is there any darkening of the wiring?	O Install the tail lamp correctly. O Remove the tail lamp on a sunny day and leave it for a while. O Install the buckin properly. C Install the wiring so that it does not darken.

Valenti LED Tail Lamp Warranty

1. The warranty period is 12 months from purchase. Installation within this period, correct installation according to instructions such as instruction manual, failure in the use state, water leakage | If this happens, we will repair it free of charge or replace it free of charge. The warranty does not cover any damage or damage to the product that occurs after purchase.

2. Even if it is within the warranty period after the end of the warranty period, I do not guarantee it in the case of the following.

- (b) When the warranty card is not presented.
- (b) When the date of purchase, customer name, or dealer name is not indicated in this document. (You can substitute documents that can prove the date of purchase, such as the receipt of the dealer at the time of purchase)
- (c) When the lexical of this book has been rewritten.
- (II) Failure, damage, water leakage due to installation work, errors in use, carelessness, week loss. (a) Failure, damage, or water leakage due to improper repair, remodeling, or disassembly.
- (h) Failure, damage, water leakage due to fire, earthquake, wind and flood damage, abnormal voltage, pollution and other natural disasters.
- (b) Failure, damage, and water leakage due to traffic accidents.
- (c) Failure, damage, water leakage due to that I used it other than a conformity car model.
- (b) Failure or damage to other parts of the vehicle.
- (N) Consumables such as valves.
- (L) Labor costs related to installation and removal. Other expenses.
- (W) Things that have been bought and sold for second-hand or transferred to a third party.

3. The warranty card will not be reissued, so please keep it carefully so as not to lose it.

4. This document is valid only in Japan.

5. The warranty is a promise of free replacement and repair under the stated terms and conditions. Therefore, this warranty limits your legal rights

We are not responsible for the content of this website.

Warranty period	Date of purchase	1.2 months from the date of the year
Your address and name		
〒		様
TEL() -		
Location and name of the store		
〒		様
TEL() -		

Valenti Japan

TEL058- 322-6700 FAX058- 398-1666

Zip code 501-6311 1881 Nagama, Kaminaka-cho, Hashima City, Gifu Prefecture